

# LA110-24S

## High-efficiency PV Module

### Technology

The LORENTZ LA-Series of PV modules offer a conversion efficiency of 17-20% due to the unique back-contact technology. As a result, our monocrystalline silicon solar cells yield a high voltage per cell, and LORENTZ modules are lighter and smaller.

In combination with an extremely low voltage-temperature coefficient, this guarantees a superior battery charging performance, even at high operating temperatures.

Exceptional low-light performance and broad spectral response further enhance energy delivery in all weather conditions, year round.

### Applications

- water pumping
- water purification systems
- remote village lighting
- solar home systems
- street and camp lights
- traffic signals
- medical facilities in remote areas
- microwave/radio repeater stations
- battery charging

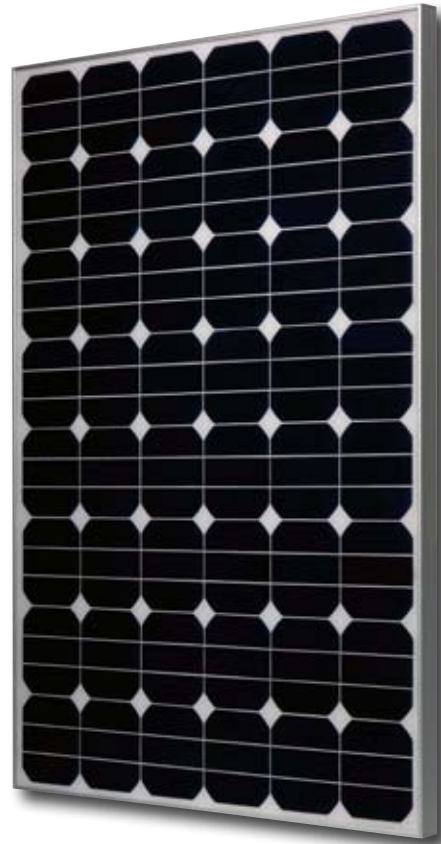

### Features

- aerospace style cell interconnects with in-plane strain relief
- advanced EVA encapsulation system with multi-layer backsheets for long-term package durability
- bypass diodes to minimize the power drop caused by shade
- high reliability

### Warranty

- Warranty: 2 years
- Performance guarantee:  
10 years (90% power output)  
20 years (80% power output)

Details according to warranty issued by LORENTZ

### Standards

LA110-24S meets the requirements for IEC and CE.



### Specifications

#### Electrical Data

Peak power	P <sub>max</sub>	[Wp]	110
Tolerance		[%]	+10 / -5
Max. power current	I <sub>mp</sub>	[A]	3.0
Max. power voltage	V <sub>mp</sub>	[V]	36.2
Short circuit current	I <sub>sc</sub>	[A]	3.5
Open circuit voltage	V <sub>oc</sub>	[V]	47.2
Efficiency of cells		[%]	17.0
Temperature co-efficient for P <sub>max</sub>		[%/°C]	-0.38
Temperature co-efficient for V <sub>oc</sub>		[mV/°C]	-132
Temperature co-efficient for I <sub>sc</sub>		[mA/°C]	3.5
Max. system voltage		[V]	750

All technical data at standard test condition:  
AM = 1.5, E = 1,000W/m<sup>2</sup>, cell temperature: 25 °C

#### Cells

Number of cells in series	72
Number of cells in parallel	2
Cell technology	monocrystalline
Cell shape	rectangular

**Electrical Performance**

**Electrical Performance**

for different temperatures, at AM=1.5, E=1,000W/m<sup>2</sup>

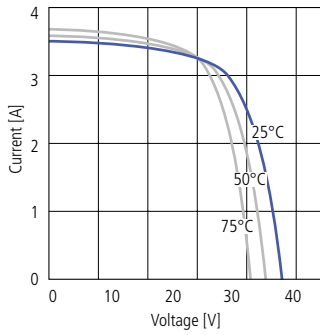

**Electrical Performance**

for different irradiation, at 25°C

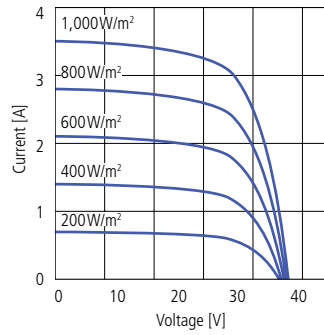

**Temperature Dependence**

of I<sub>sc</sub>, V<sub>oc</sub> and P<sub>max</sub>

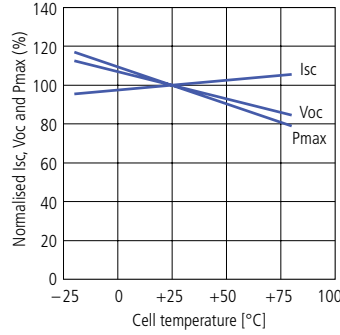

**Irradiation Dependence**

of I<sub>sc</sub>, V<sub>oc</sub> and P<sub>max</sub> at 25°C

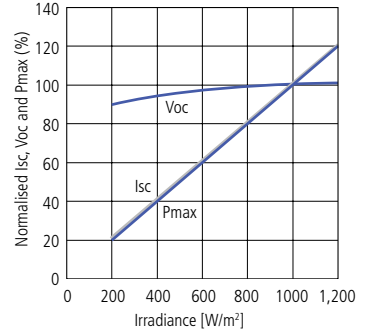

**Physical Specifications mm [in]**

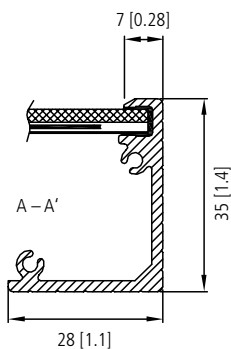
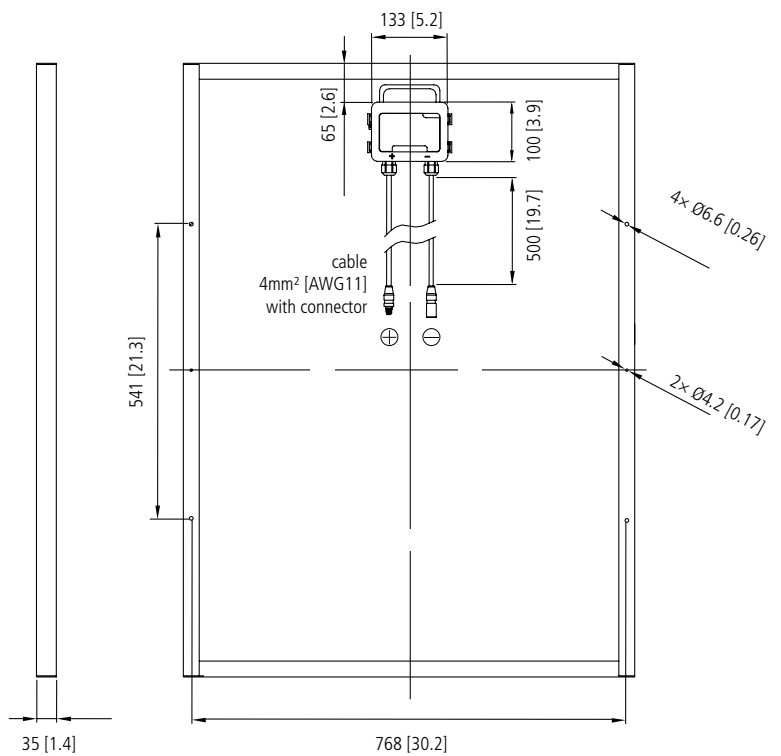
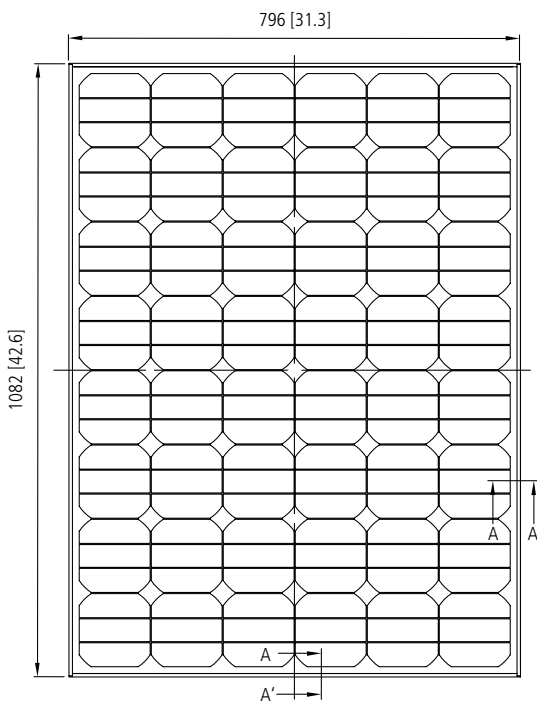

Weight	[kg]	12.0
Dimension	[mm]	796 × 1082 × 35
Cable		approx. 1 m / 40 in, 4 mm <sup>2</sup> / AWG 12
Connectors		ZJRH Cixi Renhe 05-1