

# LORENTZ S1-200 pump system

## Description

The **LORENTZ S1-200** pump system is a portable and flexible system designed to pump water using solar power.

The system has an all plugged design for simple customer self installation. All equipment is rated for outdoor use. The system consists of a submersible helical rotor pump attached to a high efficiency brushless ECDRIVE motor. The system controller digitally controls the motor and monitors the system operation. Inputs are provided for connection of accessories for system automation (dry run protection and tank full sensor).

## Features

- High-efficiency ECDRIVE DC brushless motor and high efficiency helical rotor pump
- System controller with plugged connections, integrated MPPT
- Controller with Bluetooth® connectivity for local configuration and control
- Simple S-Connect app for speed control, timers and extended trouble shooting

## Technical data

Pump system	S1-200 HR-07	S1-200 HR-14	S1-200 HR-23
Max. flow rate	1 m <sup>3</sup> /h [4 US gpm]	1.9 m <sup>3</sup> /h [8 US gpm]	3 m <sup>3</sup> /h [13 US gpm]
Max. head	40 m [130 ft]	30 m [100 ft]	17 m [55 ft]

## S1-200 controller data

Input (DC)	
Max. voltage (Voc)	55 V DC
Operating voltage	24 ... 55 V DC
Max. current (DC)	6 A
Max. PV short circuit current (Isc)	25 A
Output (DC)	
Rated output voltage	39 EC PWM 3-Phase
Max. frequency	170 Hz
Max. continuous current	6 A
Max. continuous power	250 W
Casing	
Enclosure	IP 68
Protective class	II
Sensor inputs	Dry run protection - Tank full switch or Remote tank switch
Casing material	Polycarbonate
General	
CONNECTED App	LORENTZ S-Connect
Ambient temperature	-30 ... +50 °C [-22 ... 122 °F]
Max. altitude rating	2000 m [6560 ft]
Pollution degree classification	3
Protection against	Overtemperature, overvoltage, overcurrent, short circuit, reverse polarity
Bluetooth® module	
Operating frequency	2402-2480MHz
Max. RF output power	10dBm
Miscellaneous	
Adaptor cable to MC4	2 x 2.5 mm <sup>2</sup> [AWG 14] - L = 0.5 m [1.64 ft]
Mounting screws to PV module	2 x M4.8 x16 mm [#10 x 5/8 in] - AISI 304
Butterfly hose clamp	1 x 21 to 44 mm [13/16 to 1-3/4 in] - SS

## S1-200 Controller dimensions and weights

W1	133.2 mm [5.2 in]
W2	150.0 mm [5.9 in]
W3	110.0 mm [4.3 in]
D1	43.0 mm [1.6 in]
D2	20.0 mm [0.8 in]
H1	151.7 mm [5.9 in]
H2	166.9 mm [6.5 in]
Net weight	0.3 kg [0.7 lb]

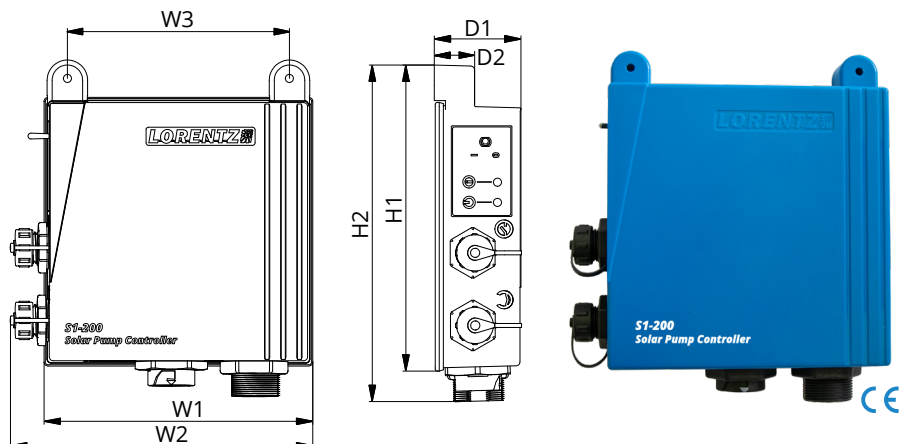

## Pump end data

Pump type	HR - helical rotor
Pump outlet	26 mm [1.0 in] - hose push connection
Min. borehole diameter	100 mm [4 in]
Max. pump end efficiency	61 %
Rotor material	AISI 630
Stator material	polyphenylene sulfide

## Water temperature range

Temp. class 2	+20 – +30 °C [68 – 86 °F]
Temp. class 3	+30 – +40 °C [86 – 104 °F]
Temp. class 4	+40 – +50 °C [104 – 122 °F]

## Motor ECDRIVE data

Rated power	0.25 kW [0.3 HP]
Motor speed	750 ... 2500 rpm
Insulation class	F
Enclosure class	IP 68
Max. motor efficiency	86 %
No. poles	8
Max. submersion	50 m [164 ft]
Max. water temperature	50 °C [122 °F]
Motor material	polycarbonate
Length of cable	15 m [50 ft]
Cable size	3 x 2.08 mm <sup>2</sup> [AWG 14]
Cable plug	3-pin male

## Pump with motor dimensions and weights

A	431.6 mm [16.9 in]
B	147.1 mm [ 5.7 in]
C	284.5 mm [11.2 in]
D	96.0 mm [3.7 in]
E	89.0 mm [3.5 in]
F	26.0 mm [1.0 in]
Pump end net weight	0.7 kg [1.5 lb]
Motor net weight	2.5 kg [5.5 lb]

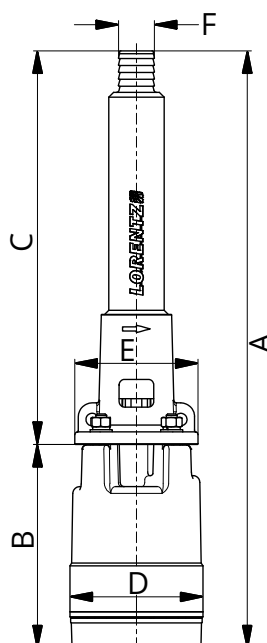

**Performance Range**

**S1-200 pump system HR-07**

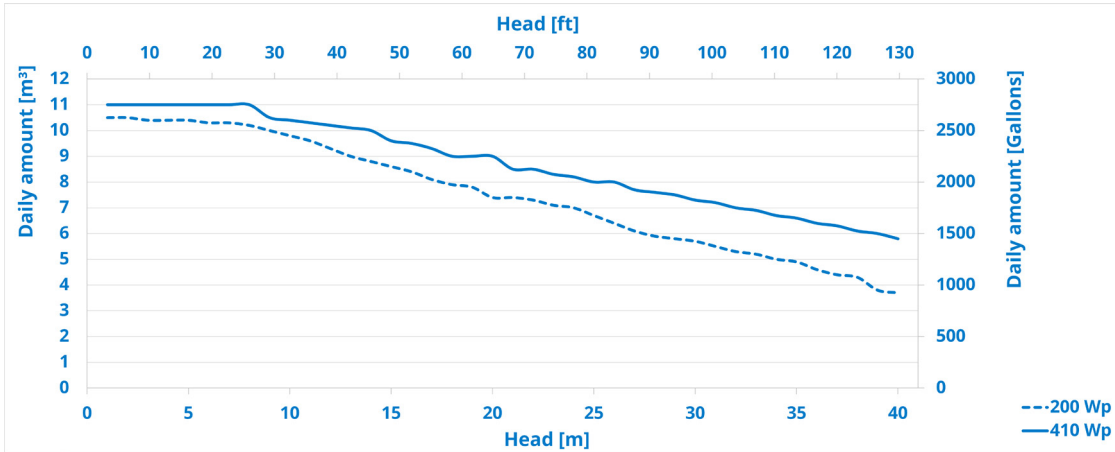

**S1-200 pump system HR-14**

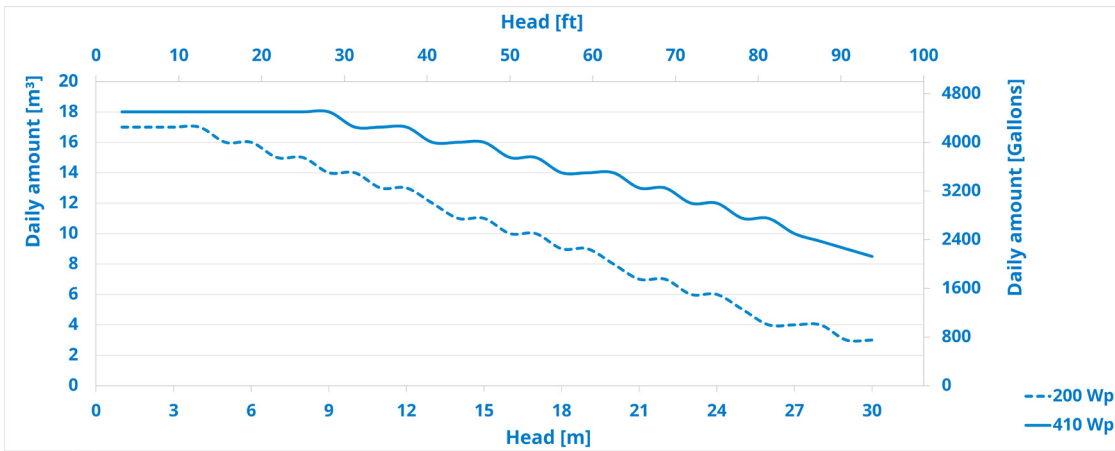

**S1-200 pump system HR-23**

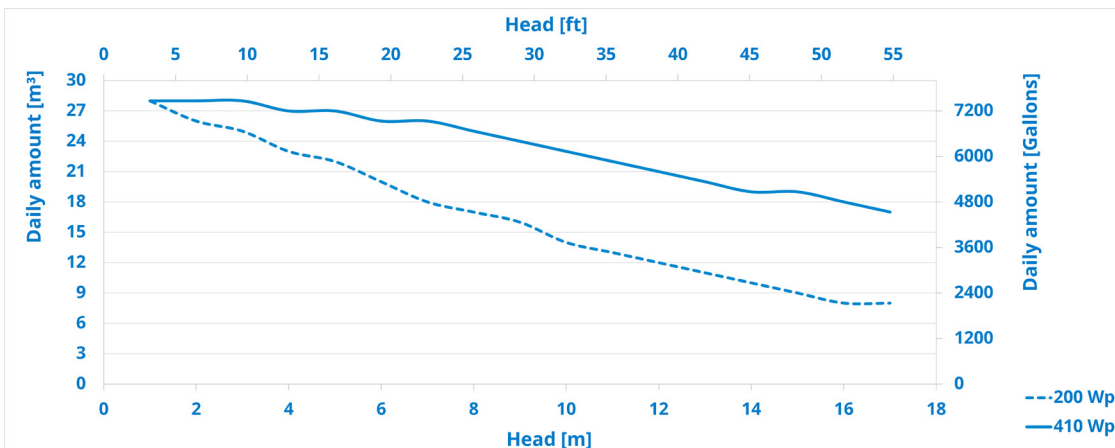

## LORENTZ S-Connect App

With LORENTZ S-Connect App easily configure and control your **S1-200** pumping system via Bluetooth® connectivity locally.

- Download it for free on Android™ devices from the Google Play Store or on iOS devices from the App Store.
- Connect to your pumping system and access multiple functions such as: Control and measurement of daily/weekly flow, speed, power, performance of connected sensors, timers setting, detailed troubleshooting scheme

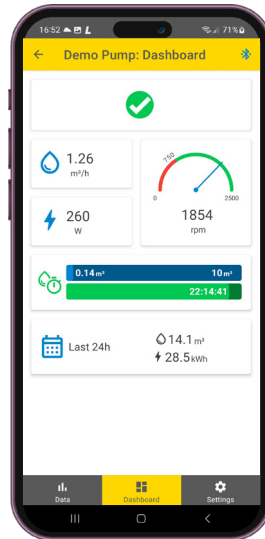

## Order and packaging information

Product name	Temp. class 2	Temp. class 3	Temp. class 4
S1-200 pump system HR-07	01-001020	01-001030	01-001040
S1-200 pump system HR-14	01-001070	01-001080	01-001090
S1-200 pump system HR-23	01-001120	01-001130	01-001140
Box content	1 x S1-200 controller		
	1 x pump with motor (includes 15 m [50 ft] cable)		
	1 x PV adapter cable MC4 (L = 0.5 m [1.64 ft])		
	1 x hose clamp (21 to 44 mm [13/16 to 1-3/4 in])		
	2 x screws - controller PV mount (M4.8 x16 mm [#10 x 5/8 in])		
	1 x manual		
Packed gross weight	7.2 kg [15.4 lb]		
Packaging dimensions [LxWxH]	580 x 170 x 150 mm [23 x 6.7 x 5.9 in]		
Packed volume	0.015 m³ [0.53 ft³]		
Systems per pallet	54		
Storage temperature	-20 °C... +65 °C [-4 °F...+149 °F]		

